

REV.	CHANGGE DESCRIPTION	DATE
A	New Issue	2018-9-14

1. MECHANICAL DIMENSIONS :

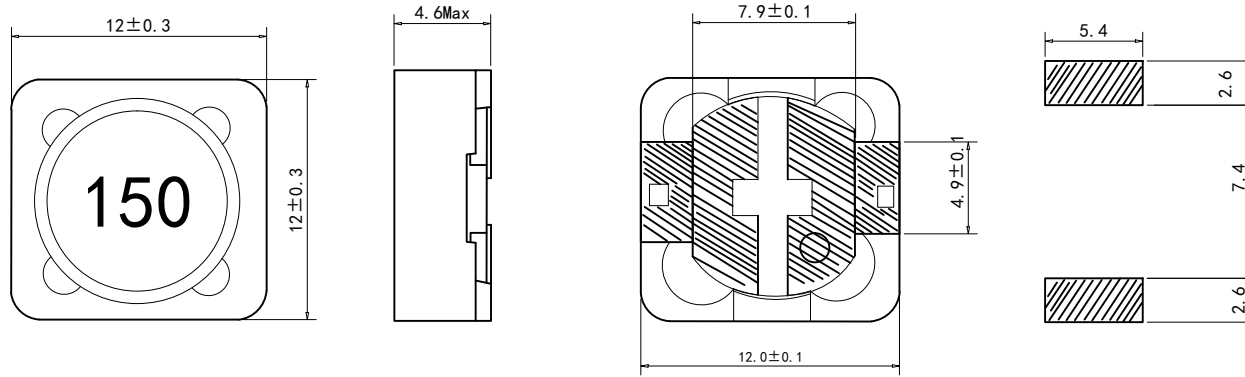

2. SCHEMATIC DIAGRAM:

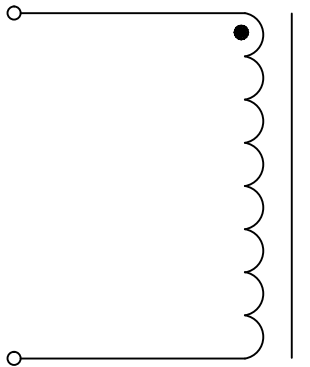

3. ELECTRICAL REQUIREMF :

TEST NOTES: (25° ±5° C)

- LX: (100KHz, 250mV) 100%
PINS: (1. 2)=15±20uH
- Isat: 3. 2A (L≥LOA*65%) 100%
- DCR: (100KHz, 100mv) 100%
PINS: (1-2)= 60 mΩ MAXIMUM
- OPERATING TEMPERATURE -25° C TO 80° C

TAG

泰安吉科技(深圳)有限公司
TAG TECHNOLOGY CO., LTD.

A4
SIZE

TAG PART NO.:
S841-H124R-150M

VENDOR PART NO.:

Drawn: Zhang Xue

Designed: Yang Tian

Approved: Deane

Date: 2018-9-14

THESE DRAWINGS AND SPECIFICATIONS ARE THE PROPERTY OF TAG TECHNOLOGY CO., LTD. AND SHALL NOT BE REPRODUCED OR USED AS THE BASIS FOR THE MANUFACTURE OR SELL OF APPARATUSES OR DEVICES WITHOUT PERMISSION.



DESCRIPTION:
Power Inductor

UNIT	mm[inch]	USED ON	
SHEET	1 OF 1	REV.	A